

**You Are An Acolyte!**

**A Leader's Guide  
to  
Training Acolytes**

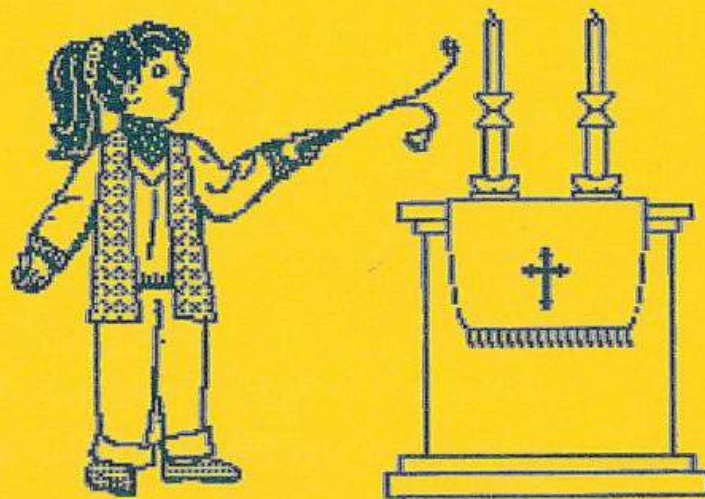

**Revised Edition  
Written and Illustrated by  
Mark and Lisa Caldwell-Reiss**

You Are An Acolyte!

A Leader's Guide  
to  
Training Acolytes

Revised Edition  
Written and Illustrated by  
Mark and Lisa Caldwell-Reiss

LTS Bookstore  
Lexington, Kentucky

1999

Margin Notes:

Notes in the margins  
appear in the  
leader's guide only.

## INTRODUCTION

Children have an important place in the ministry of the church. When serving as acolytes, children lead us into worship. They are ministers of the light as they call us to gather in God's presence. As they carry the light out, they call us to carry God's presence to the world. Their light of hope inspires our worship. Their unique approaches to their ministry enrich our congregations.

Training is important to establish confidence and competence among acolytes in their ministry among us. This packet is based on activities used in training a group of acolytes ranging in age from 6 to 12 years within the setting of a Christian Church (Disciples of Christ) congregation. Our goal in these activities was to introduce acolytes to their ministerial role and acquaint them with the church and liturgy in which they serve.

Because acolytes serve in the sanctuary, the training elements of this packet take place primarily in the sanctuary and make use of the actual objects acolytes experience in worship service. Adult participation in these events can nurture the natural awe and mystery children feel about the sanctuary into a growing sense of respect and purpose.

Many churches have acolytes wear robes and/or stoles which identify to everyone the importance and authority of the acolytes' role. We have found that children in our congregation are most comfortable wearing a stole without a robe. With stoles, no one has to worry about sizes. On the other hand, the uniformity of robes can put to rest differences of opinion on appropriate clothing for serving. In either case, the stole and/or robe can instill in the acolytes the confidence of a clearly defined role.

Even within a denomination, each congregation can be quite unique in its worship style and flavor. Therefore, many opportunities arise to personalize this material to a particular church environment. Some of these opportunities will be noted in the margins. We hope you will find these ideas readily adaptable and quite useful.

We have included in this packet the following: a handbook for acolytes, the program and materials for an acolyte training party, a coloring book and a stole pattern.

The chief revision to the original was to include and discuss "carrying the light out" as one of the responsibilities of an acolyte.

**Handbook:**  
Making the Cover

Take an instant snapshot of the child when he/she is contacted to be an acolyte. Afix the picture to the front of the handbook. Yearbook or school photos will also work although nothing replaces the fascination of an instant photo.

**You**



**Place Instant Photo Here**

**Are an Acolyte**

## YOU ARE AN ACOLYTE.

As an acolyte you have a very important ministry. The ministry of an acolyte has four parts.

1. Light the candles on the communion table at the beginning of worship.
2. Carry the light out at the end of worship.
3. Help people worship God.
4. Help keep the communion table neat and clean.

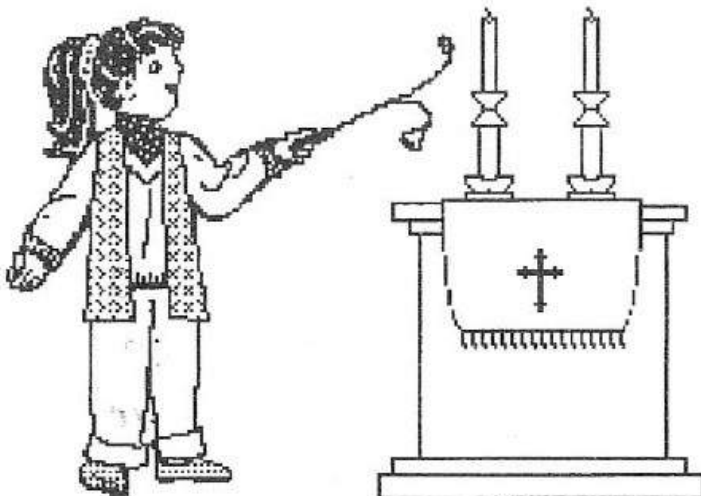

### Handbook: Its Purpose and Use

The handbook is a recruitment tool and can be presented as potential acolytes are approached. The handbook clearly defines the church's expectations. These guidelines will help the child decide whether or not to become an acolyte.

The handbook is designed to be read to, by or with parent(s) or another adult. Thus, both the children and the adults with whom they attend church are aware of the role and responsibilities of the acolytes.

## LIGHTING THE CANDLES

As an acolyte, you will light the candles on the communion table. You will light the candles at the beginning of worship. In order to do this, you will get ready before worship begins.

Acolytes need to get ready at: \_\_\_\_\_.

Worship begins at: \_\_\_\_\_.

Acolytes meet in the: \_\_\_\_\_.

What do you need to light the candles?



You will need a candlelighter and an adult. The adult will need matches or a lighter to help you light the wick of the candlelighter. Once the candlelighter is lit, you are ready. Wait for your cue!

## CARRY THE LIGHT OUT

Who puts the candles out at the end of worship? YOU DO!

At the end of worship, before you put the candles out, light the wick of the candlelighter again. Then cover each candle gently with the bell of the candle lighter.

As you walk out, carry the light carefully in front of you. Put the flame out once you are outside the sanctuary. Return the candlelighter to its place.

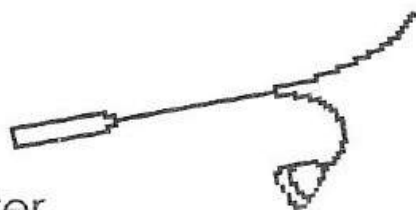

The candlelighter  
belongs:

---

Remember, God does not leave  
when the flame goes out!



## HELP PEOPLE WORSHIP GOD

Worship begins when you light the candles. When people see you light the candles, they know it is time to think about God. People get quiet.

Now, they are ready to hear God's word, to pray and to sing songs that praise God. All of this begins when you light the candles.

Worship ends when you put the candles out. When people see you carry the light out, they know that God goes with us as we leave.

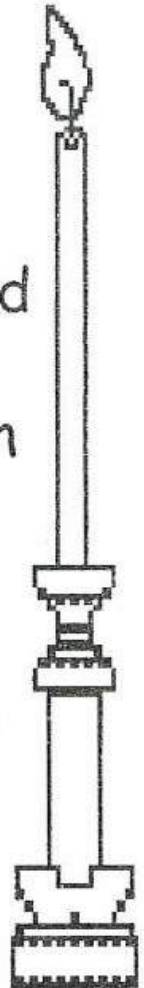

Jesus taught his disciples that he is the light of the world. When you light the church candles, you help people think of Jesus. The candlelight reminds us that God and Jesus are always with us. All the world can see God's love and light in us!

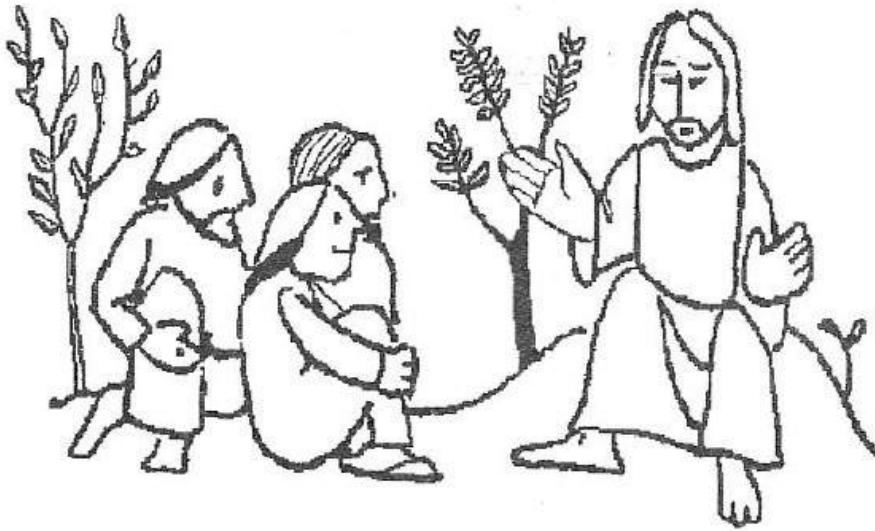

This is why your ministry as an acolyte is important to the church. You help people worship God.

## KEEPING THE COMMUNION TABLE CLEAN AND NEAT

Acolytes also help keep the communion table clean and neat. Before church, you will check the communion table.

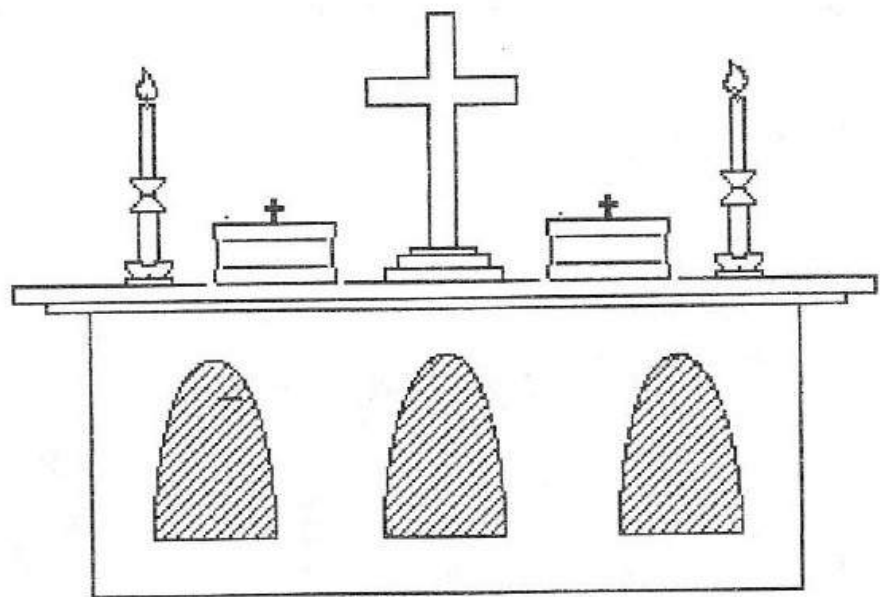

You may straighten the table cloth. You may remove stray books or papers that are not needed. If you see spills or crumbs, find an adult to help you tidy up.

## YOU ARE AN ACOLYTE

The people in the church need you. As an acolyte, you help the church in four ways. Can you remember what they are?

1.

2.

3.

4.

***You are an acolyte and you do very important things!***

## A Prayer for Acolytes

*Dear Lord,*

*Let the light we carry  
in our hands  
show everyone that you are al-  
ways with us.*

*Let the love we carry  
in our hearts  
show everyone that you  
truly love us all.*

*Amen.*

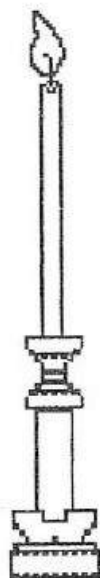



## Training Party: Purpose and Plans

After the acolytes have been recruited and have had time to read the handbook, a fun training activity will help them learn the tricks and trials of lighting the candles. This time will also familiarize them with the church sanctuary.

At this party, children and adults are introduced to the acolyte ministry in a supportive and collaborative way. Training and fellowship are as important to acolyte ministry as to the ministries of elders, deacons and teachers.

## ACOLYTE TRAINING PARTY

### **Gathering:**

Everyone gathers in the sanctuary.

### **Opening Prayer:**

Read in unison "A Prayer for Acolytes" from the Handbook. If non-readers are in the majority, teach the prayer before hand or use a prayer they already know such as "The Lord's Prayer."

### **Scripture:**

Have an adult familiar to most of the children (such as a teacher or an elder) read a very short passage such as: Matthew 5:15-16, John 8:12 or 9:5, Psalm 119:105, etc.

### **Game:**

Have everyone present play the "Hunt and Match" game (page 16) together.

### **Training:**

Pastor (and/or acolyte leader) and acolytes practice lighting the candles and putting them out. One or two adults remain to help.

(Remaining adults go to an appropriate area to prepare craft time.)

### **Craft Time:**

Everyone makes and decorates an age-appropriate candle craft to take home. Some examples are: Moravian Christingles, Advent wreaths, candle holders, luminaries, etc.

### **Snack Time**

### **Devotion:**

The pastor or acolyte leader shares a short story or meditation on the meaning of light and the role of the one who brings the light.

### **Parting:**

Everyone sings a simple song, such as "This Little Light of Mine" or "I Am the Light of the World"\* as the candle crafts are lighted. This song may be used as the acolytes' theme song at later events.

\*"I Am the Light of the World," lyrics and music by Jim Strathdee, Desert Flower Music, 1969, #469, The Chalice Hymnal, Daniel Merrick and David Polk, eds., Chalice Press, 1995.

#### **Some sources for candle crafts:**

1. Before and After Christmas. Debbie Trafton O'Neal. Augsburg Fortress, 1991.
2. Before and After Easter. Debbie Trafton O'Neal. Augsburg Fortress, 1992.
3. 101 Things to Do for Christmas. Debbie Trafton O'Neal. Augsburg Fortress, 1994.
4. "Christingle: An Intergenerational Christmas Eve Celebration from the Moravian Tradition." Kevin Hackett. Reformed Worship: Resources for Music and Liturgy, #37. September, 1995. p.18-25.

### **Training Party: Purpose and Plans**

The party is also a good time to have a schedule handy. Adults can check their calendars and choose the services for which their child(ren) will be available to serve.

Consequently, it is a good idea to have such an event every six months or so.



## Hunt and Match Game: Materials

\*2 sets of Game  
Cards divided into  
pairs

\*Poster sized  
sketch of the  
empty sanctuary

\*Easel

\*Masking Tape

\*Clear Tape

Note: You will  
need at least one  
pair of cards for  
every player.

Photocopy two sets  
of Game Cards  
onto 8.5 x 11 card  
stock (four cards  
per sheet). Here is  
a great opportunity  
to add sketches of  
items present in  
your sanctuary but  
not included here.

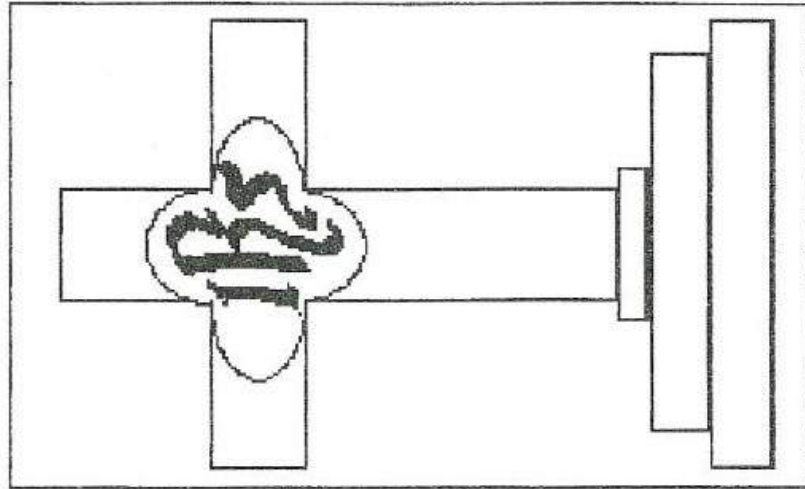

Cross

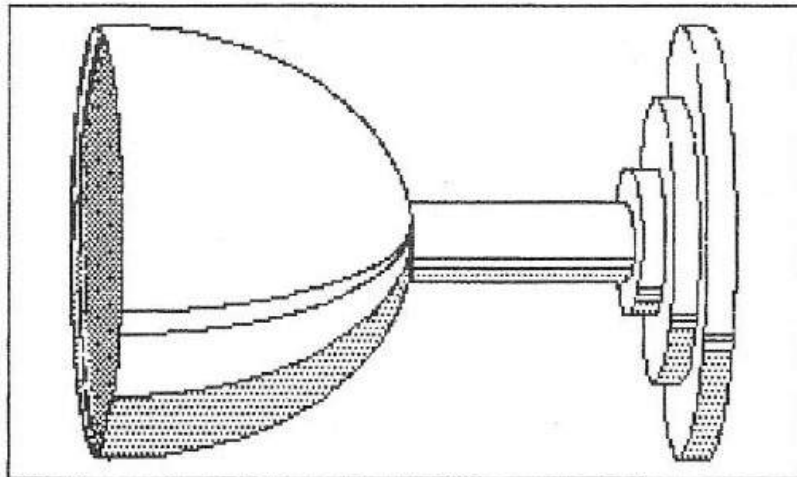

Chalice

Hunt and Match  
Game:  
Set-Up

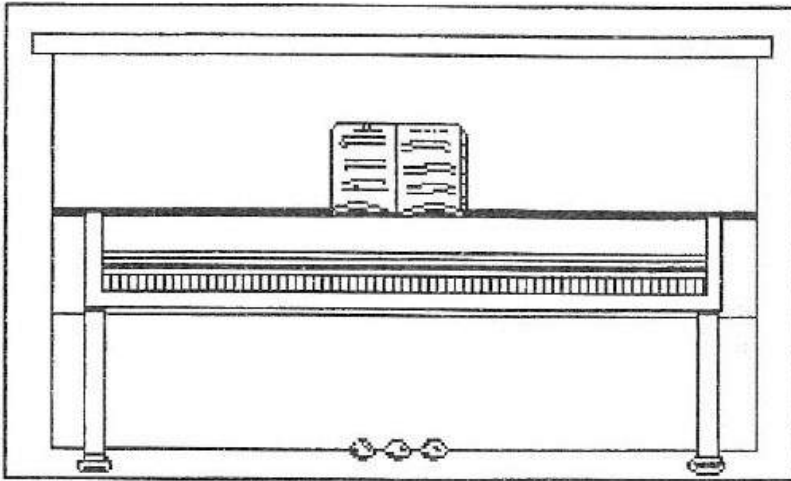

Piano

Before everyone arrives, place one card from each pair on the object or area in the sanctuary. (Use the masking tape.) All objects should remain where they normally are during worship. The card should be accessible but not obvious.

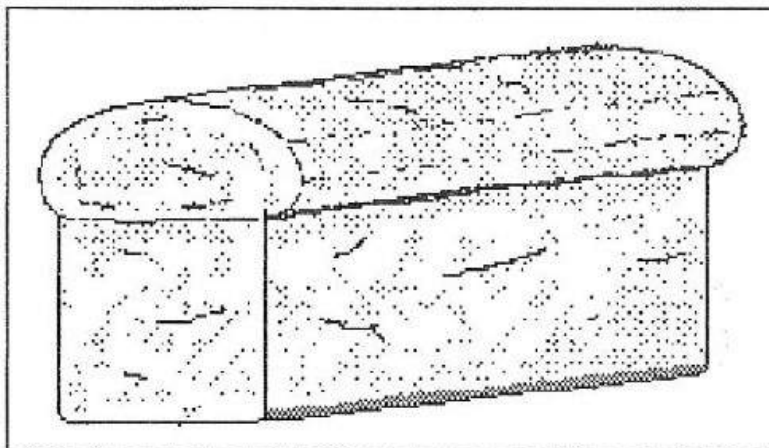

Bread

Place the sketch of the sanctuary on an easel near your gathering area.

## Hunt and Match Game: Playing

When you are ready to play, give each person a card from the remaining stack. On a signal, everyone begins to search for the match to his or her card. Helping each other is a good idea.

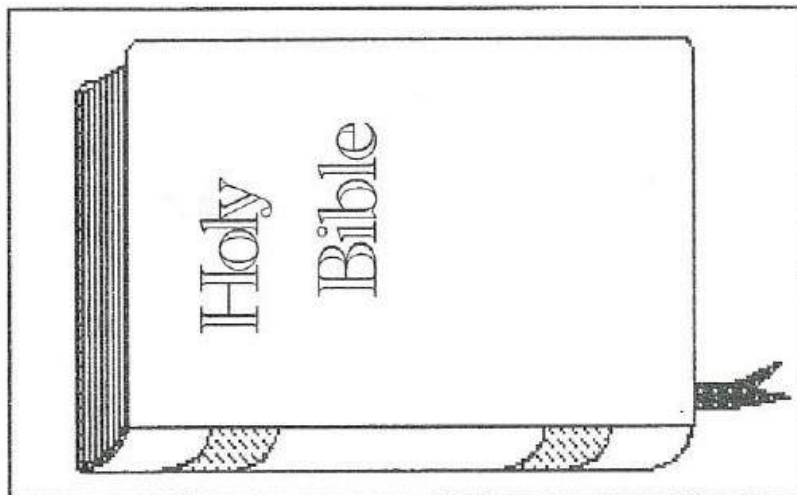

Bible

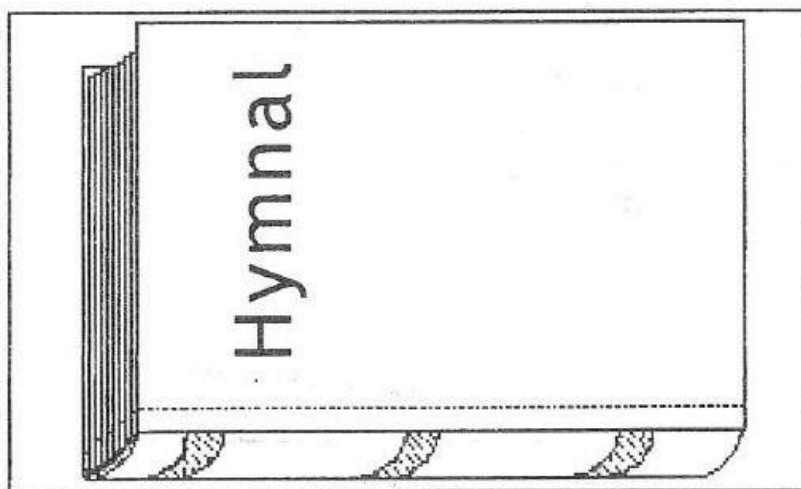

Hymnal

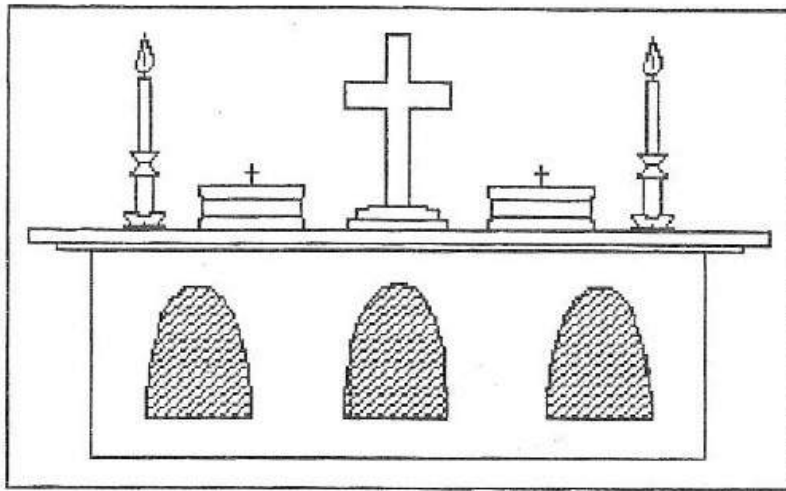

Communion Table

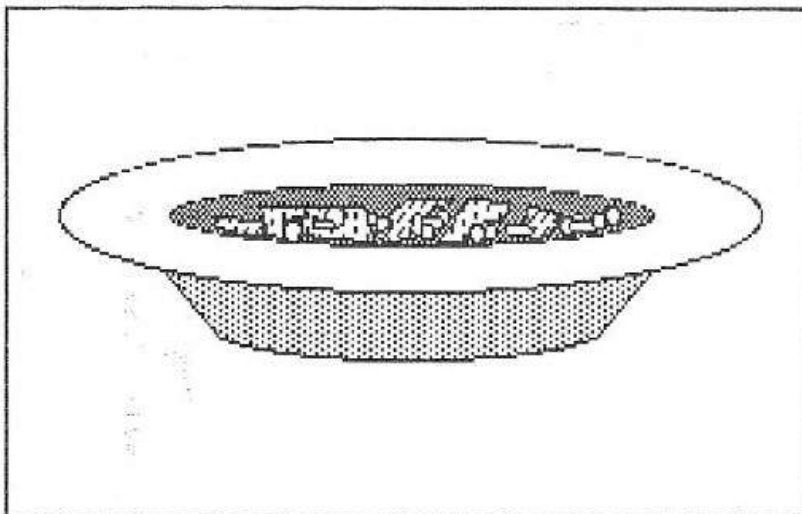

Offering Plate

Hunt and Match  
Game:  
Conclusion

When all the cards are found, players sit down. One by one, they place their cards on the poster with the clear tape. Each player can tell where they found their match. As players place their cards, have everyone discuss the function and meaning of each object or area.

Hunt and Match  
Game

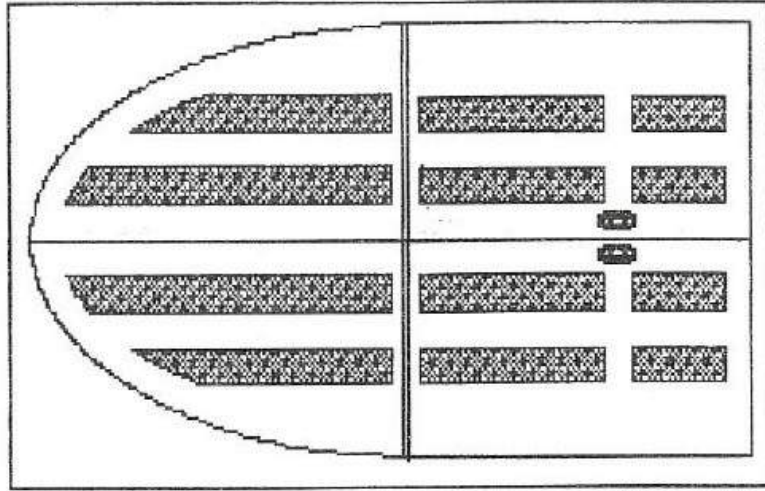

Door

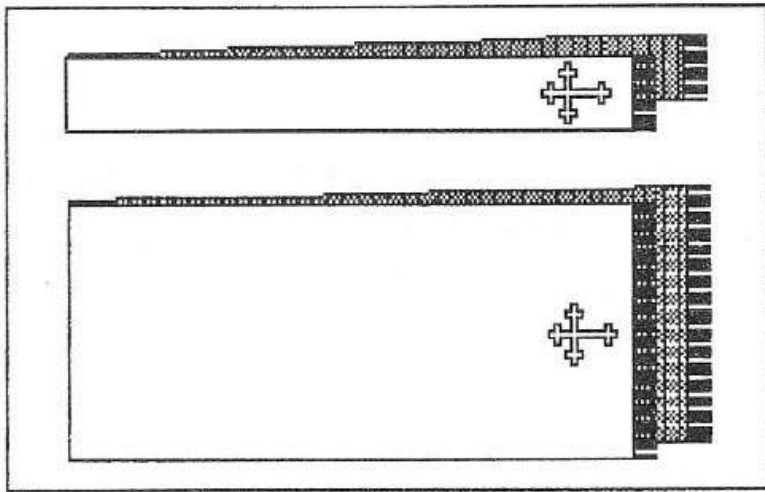

Paraments

# Hunt and Match Game

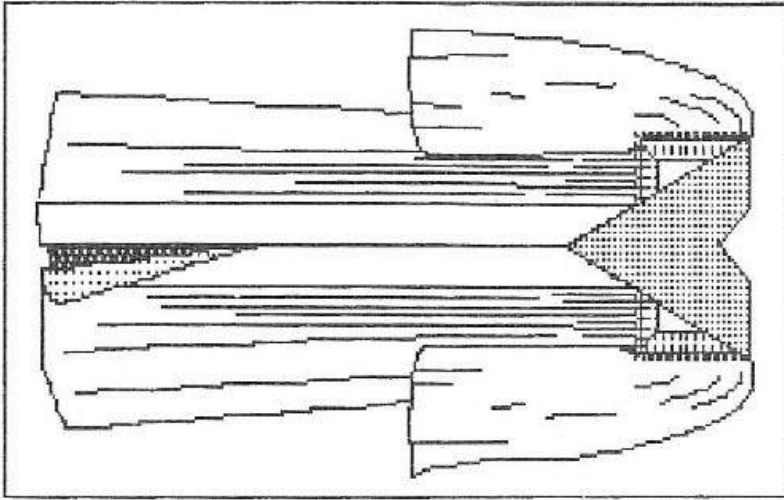

Choir Robe  
and Stole

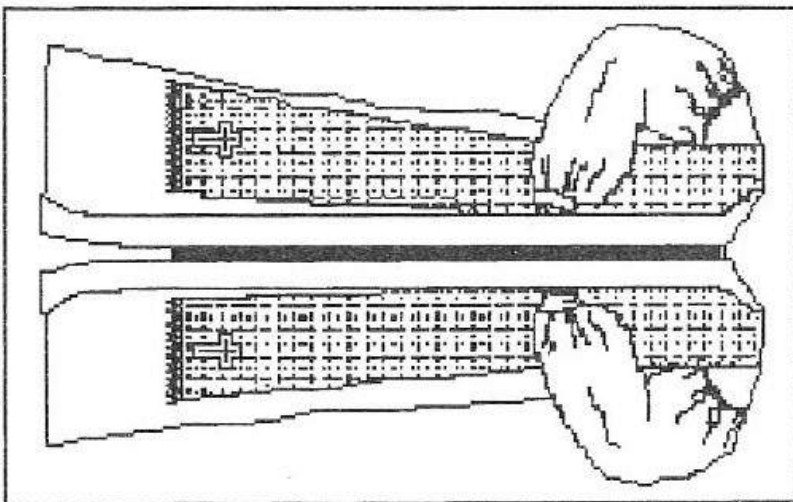

Minister's Robe  
and Stole

Hunt and Match  
Game

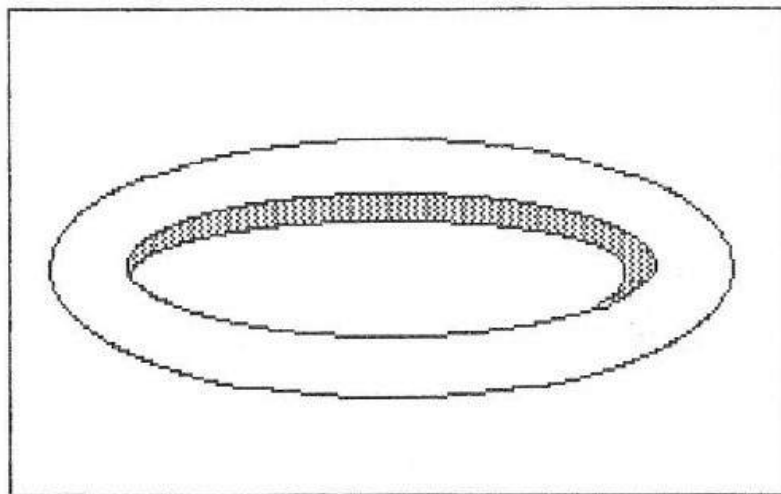

Paten

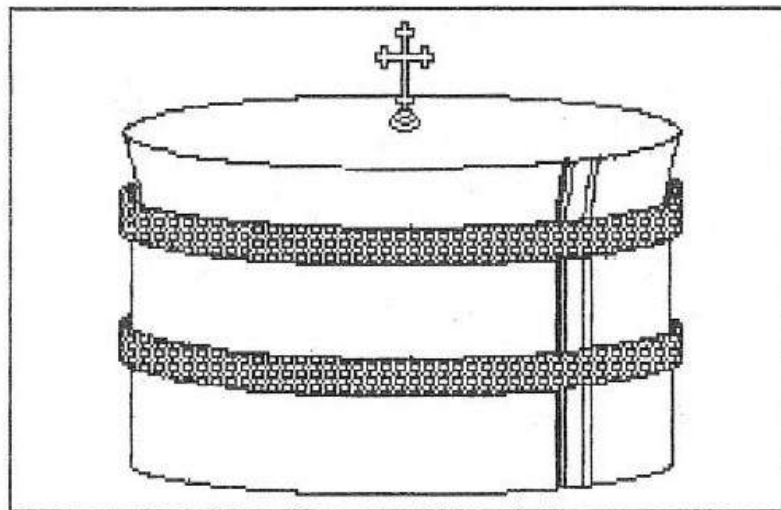

Communion Trays

Hunt and Match  
Game

Candelighter

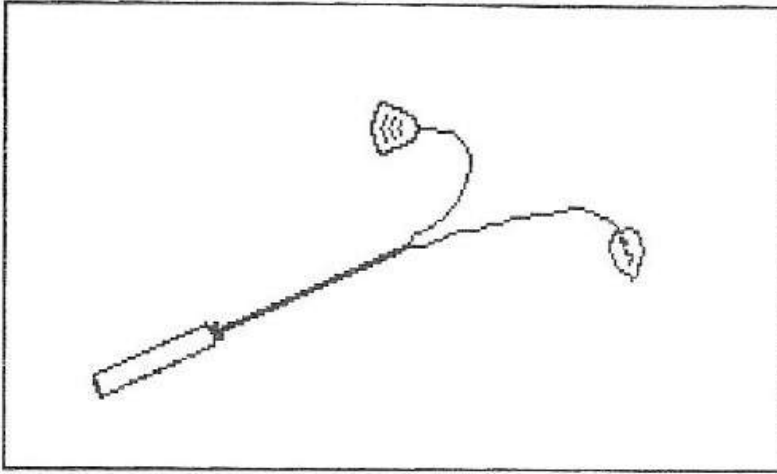

Candles

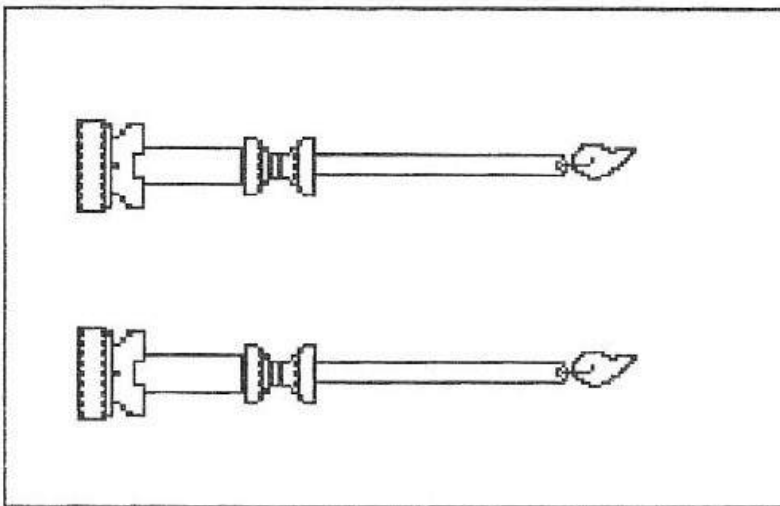





## You Are An Acolyte

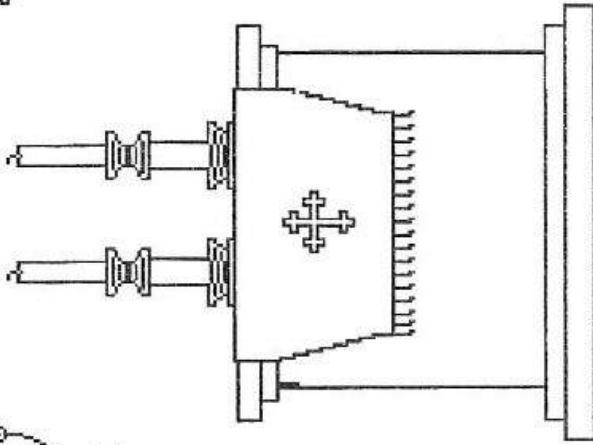
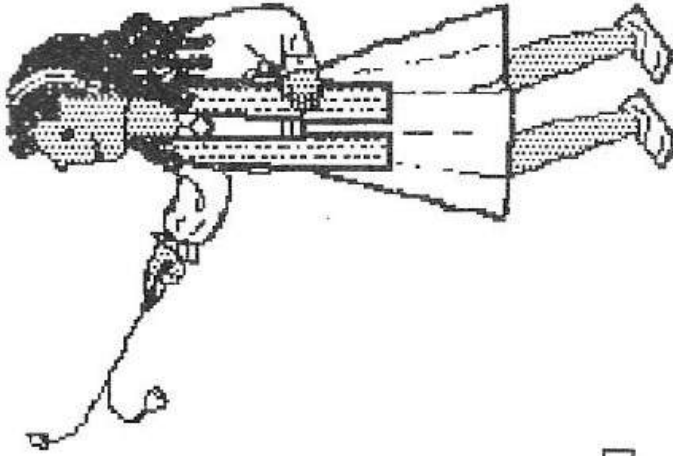
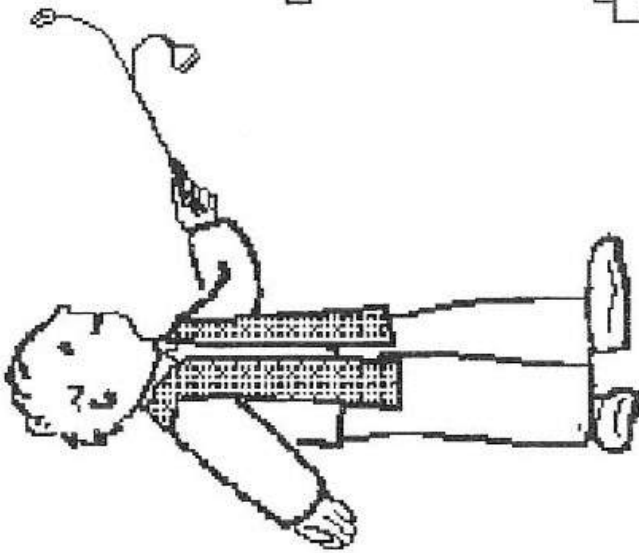

## Let It Shine!

### Coloring Book: Cover

The coloring book is an object which can be taken home and shared with parents, siblings, friends and grandparents to reinforce familiarity with the sanctuary environment.

**Coloring Book:**  
Inside Cover

A picture of your church building, door, stained glass window, a special logo or meaningful symbol identifying your congregation can be inserted here.

**Doors**

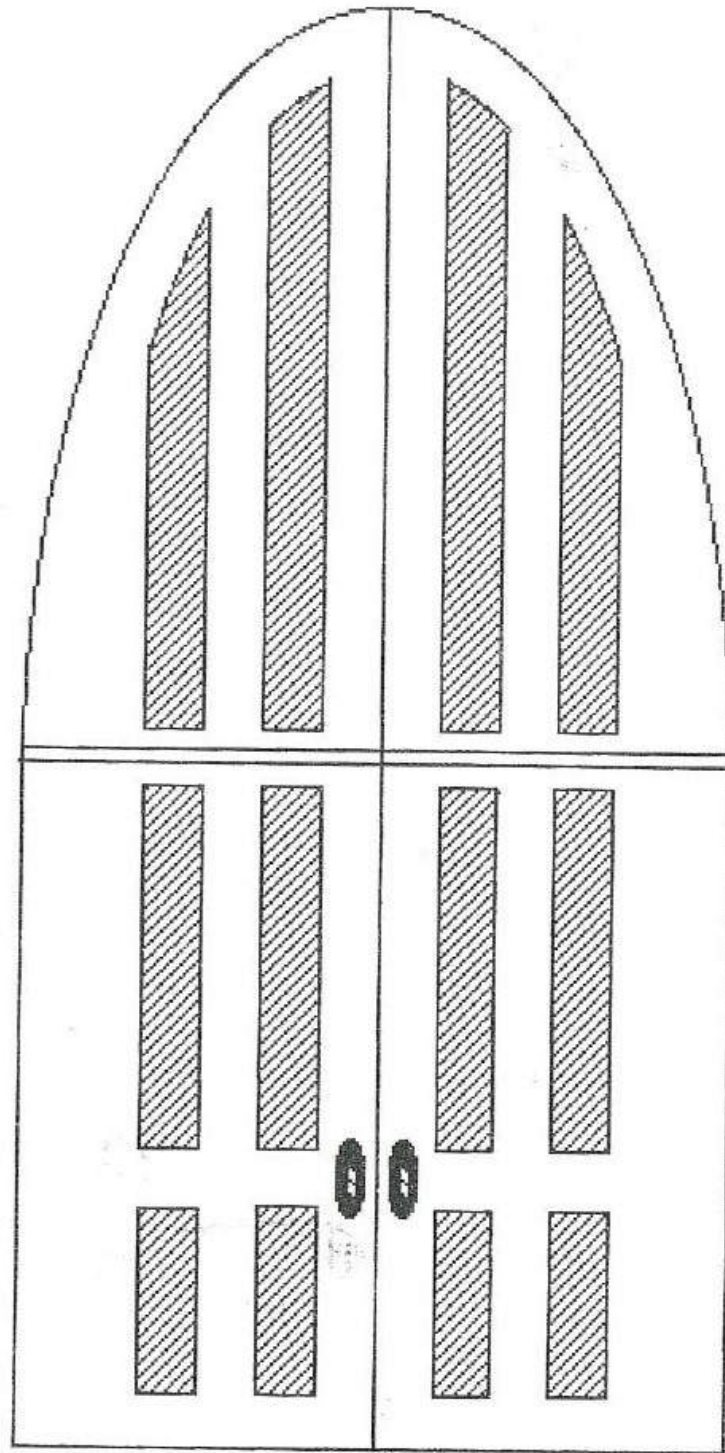

Communion Table

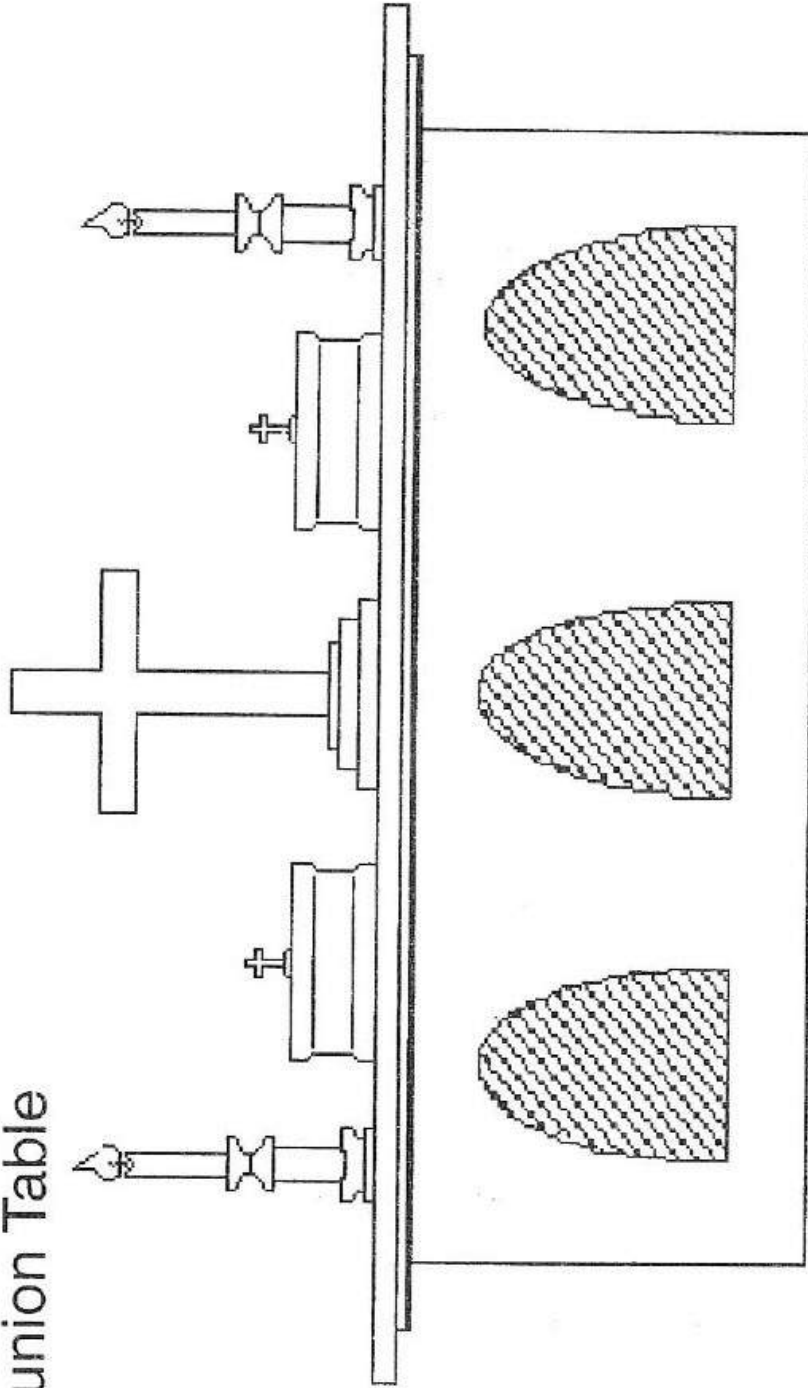

Cross

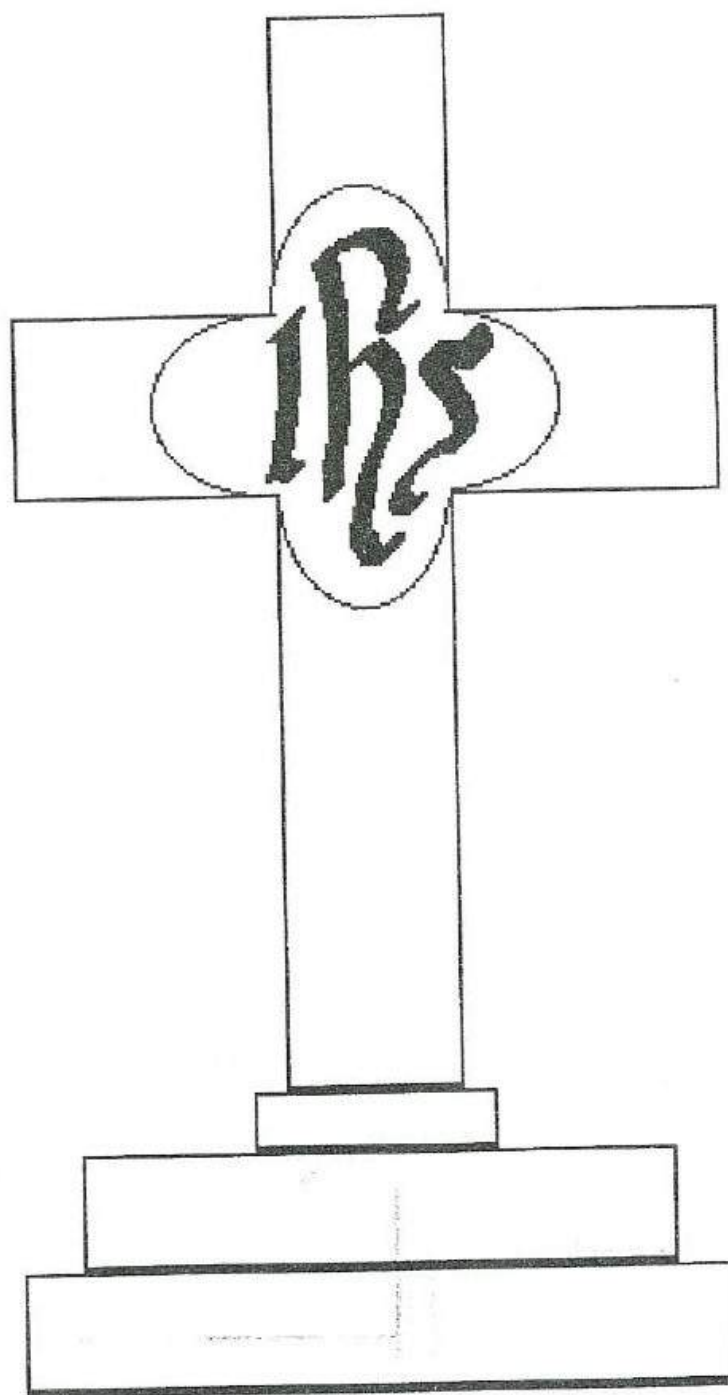

# Paraments

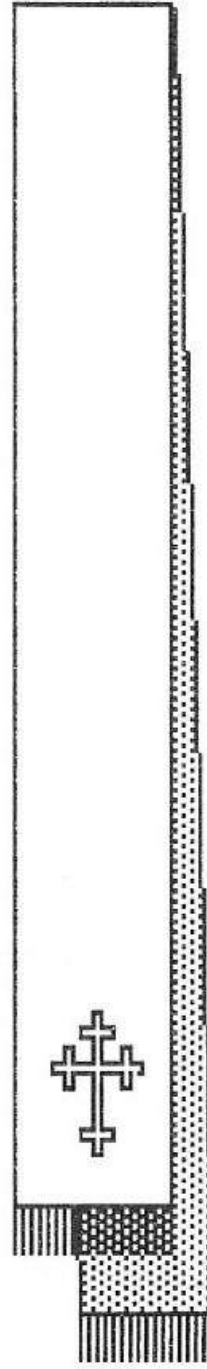
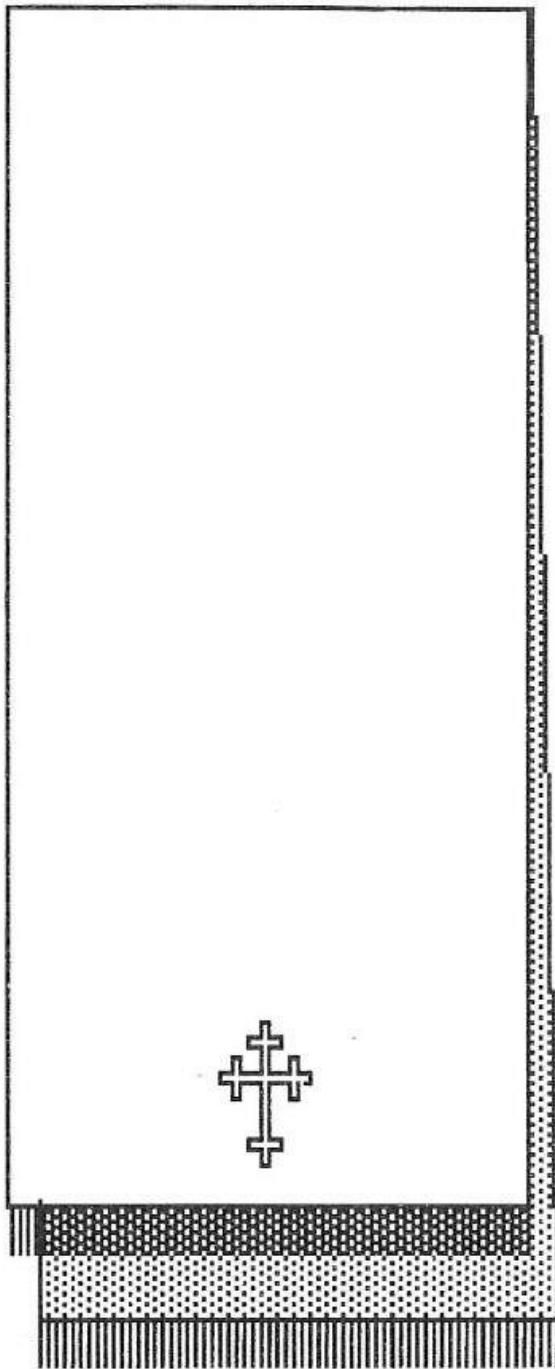

Candles

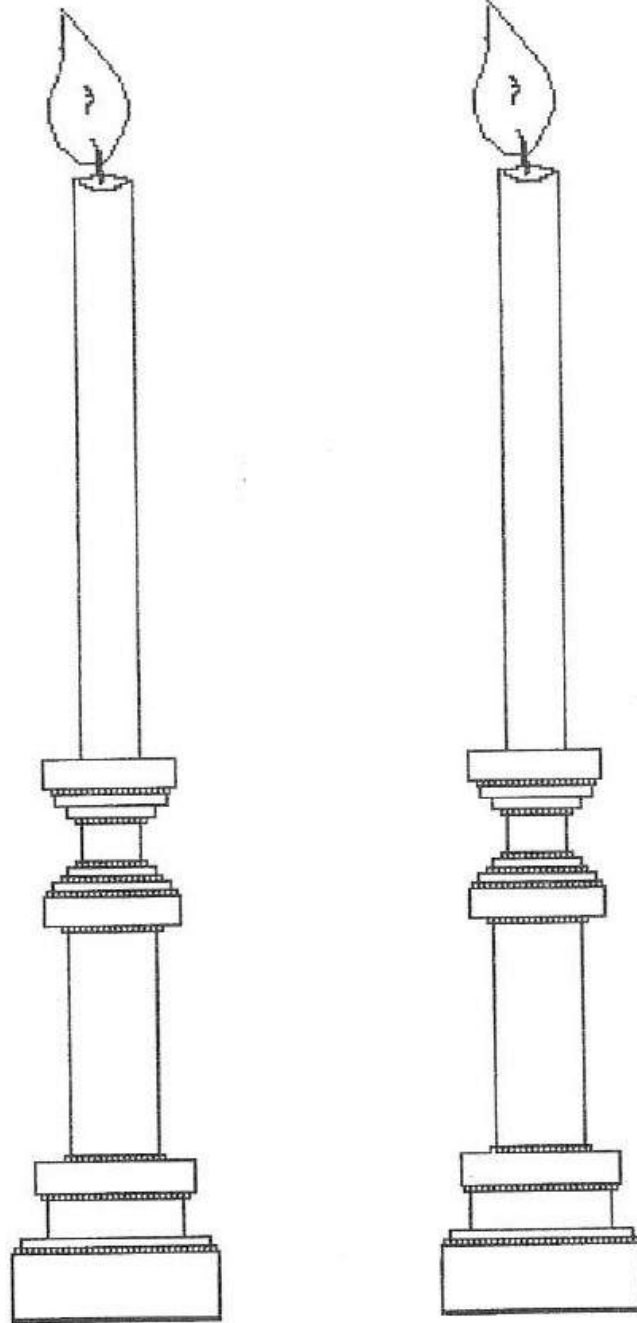

# Candlelighter

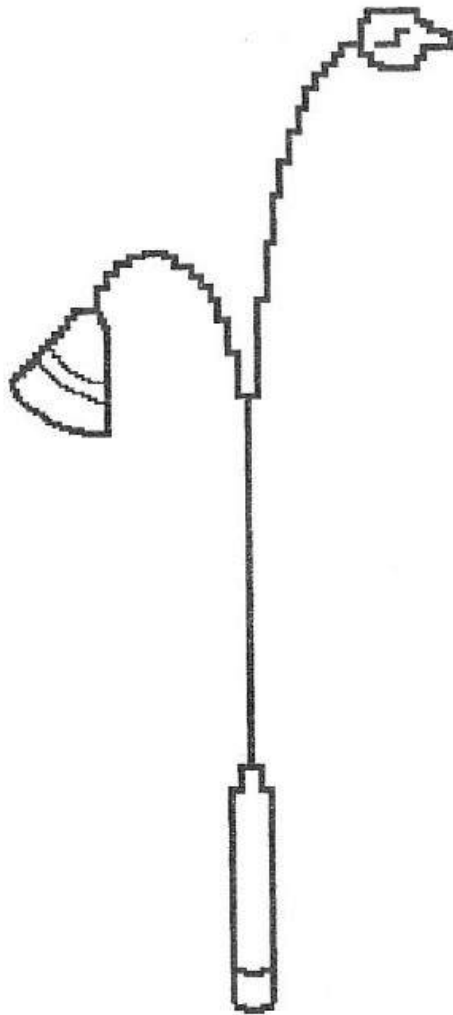

Coloring Book:



Chalice (Cup)

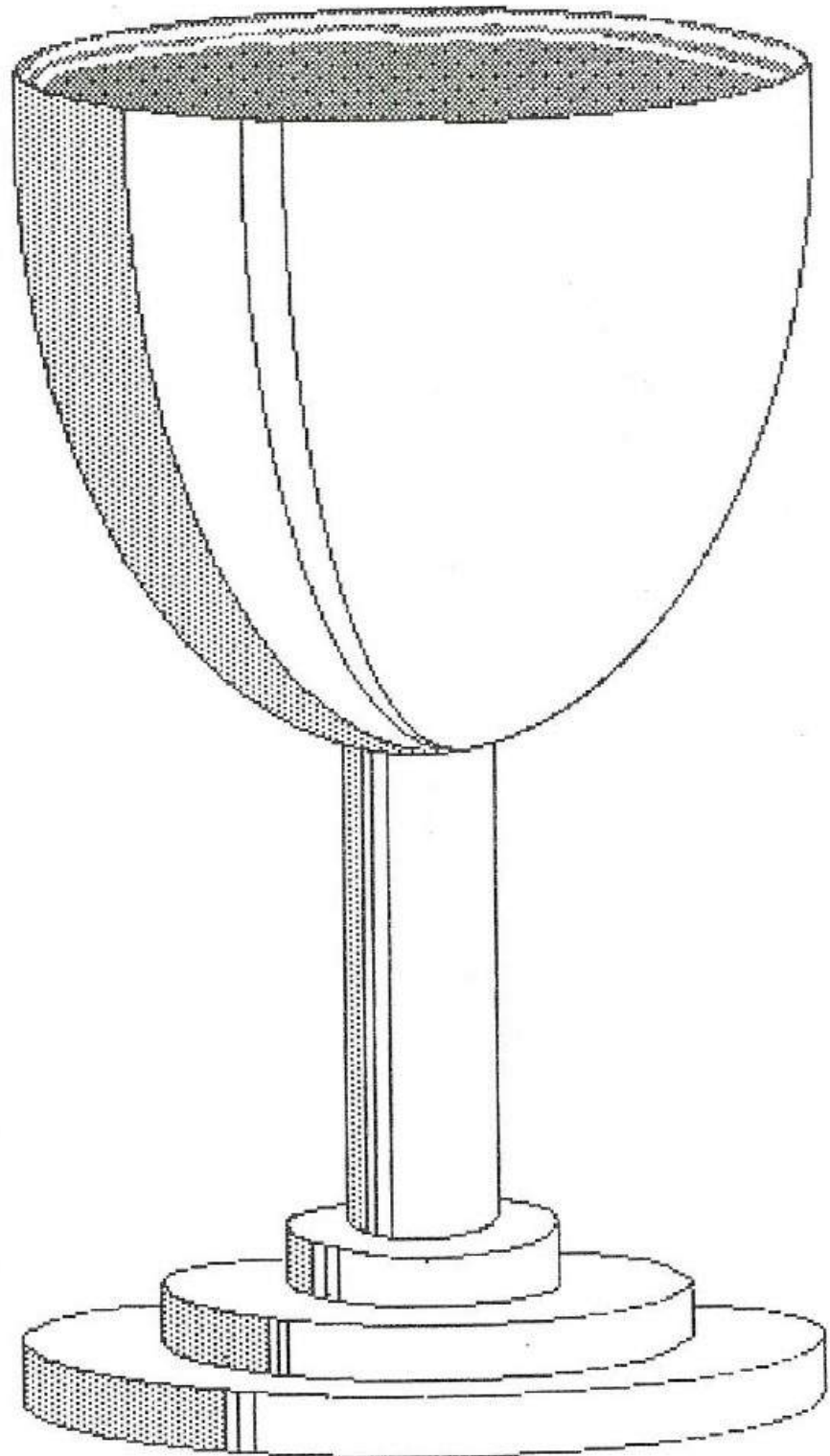

# Paten (Plate)

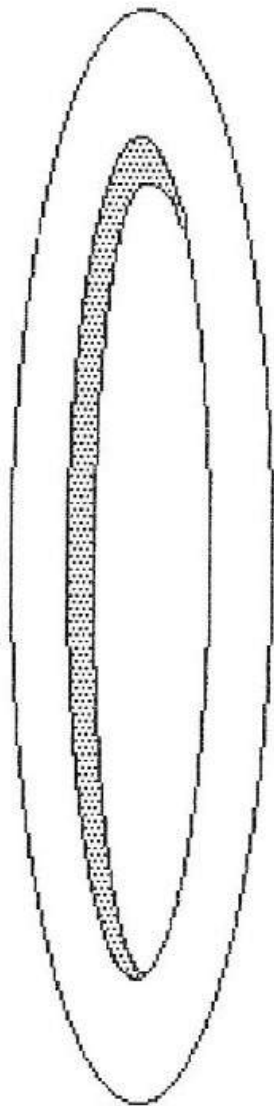

*Patens, usually made of silver, gold, or copper, were used to hold the Eucharist.*

Coloring Book:

Loaf of Bread

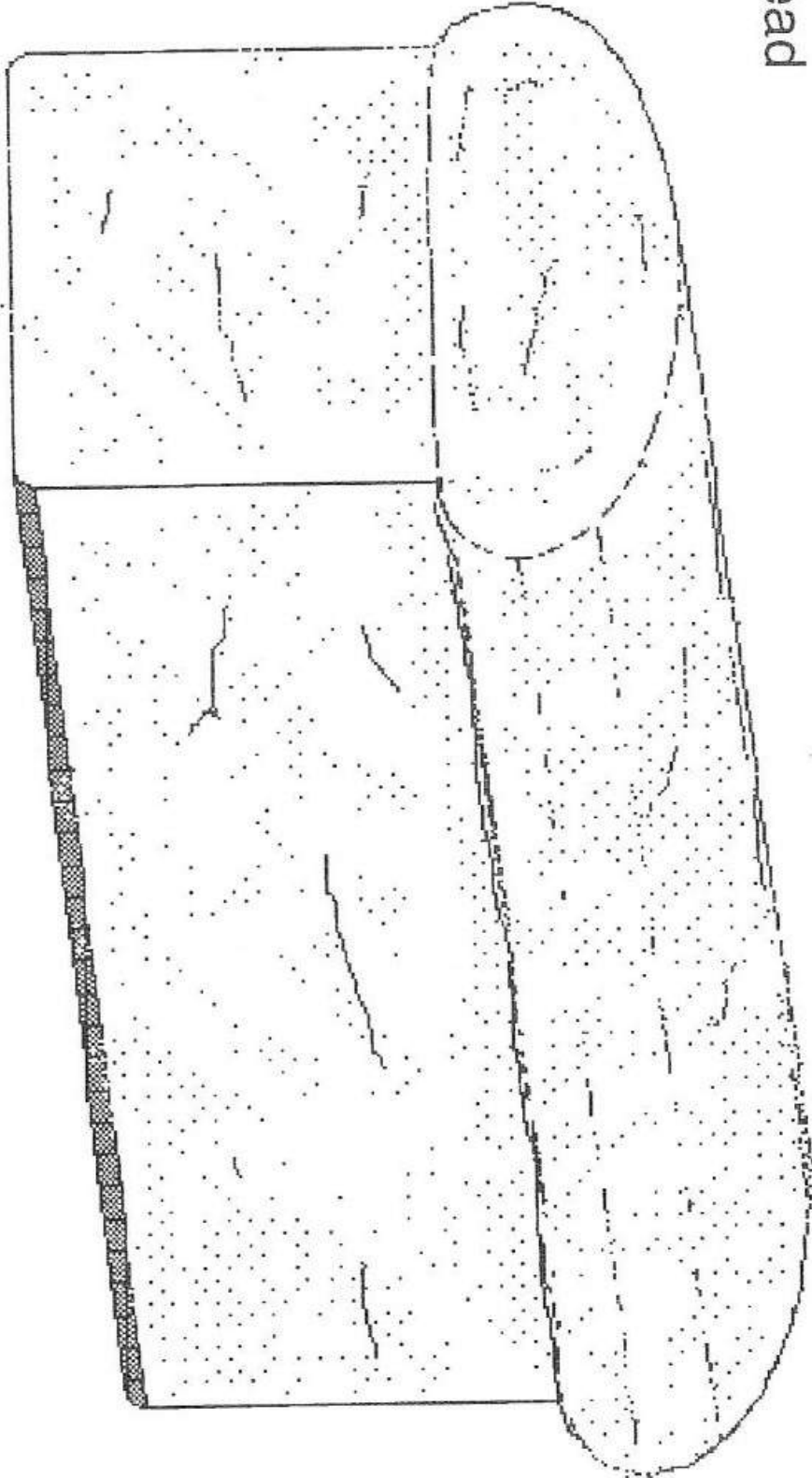

Communion Trays

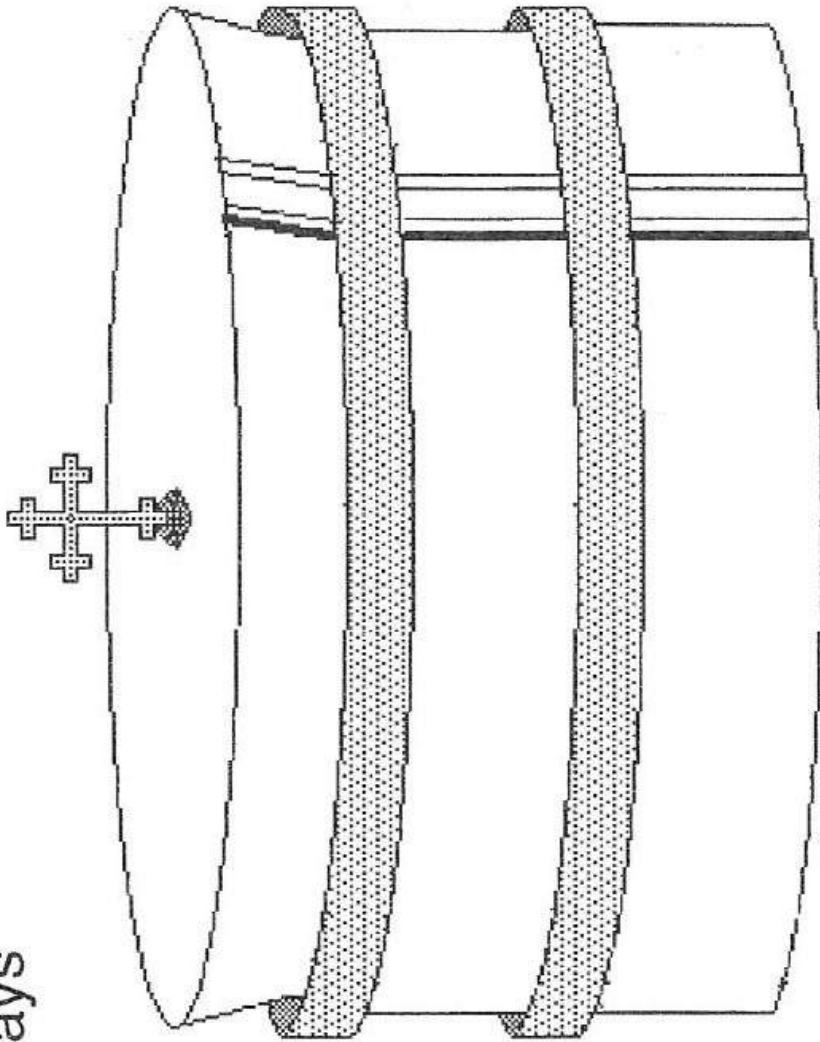

Coloring Book:

Coloring Book:

Hymnal

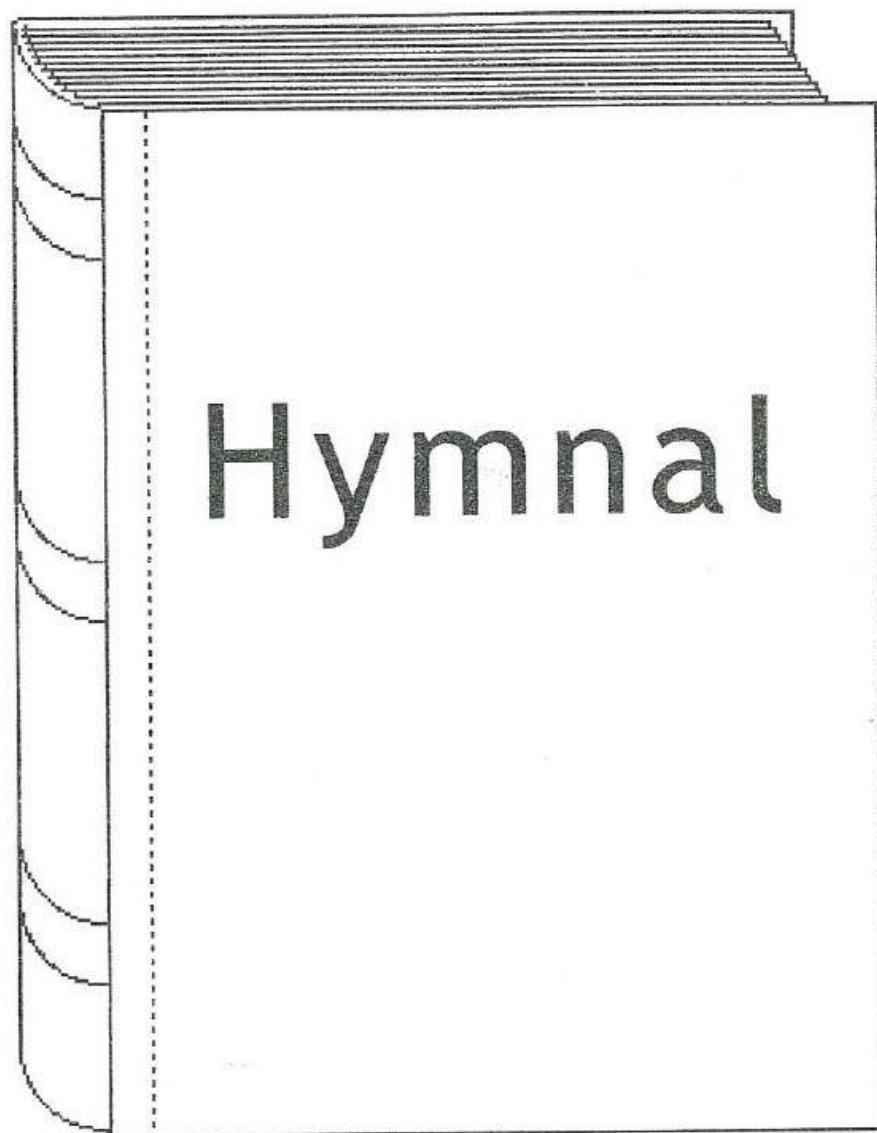

Bible

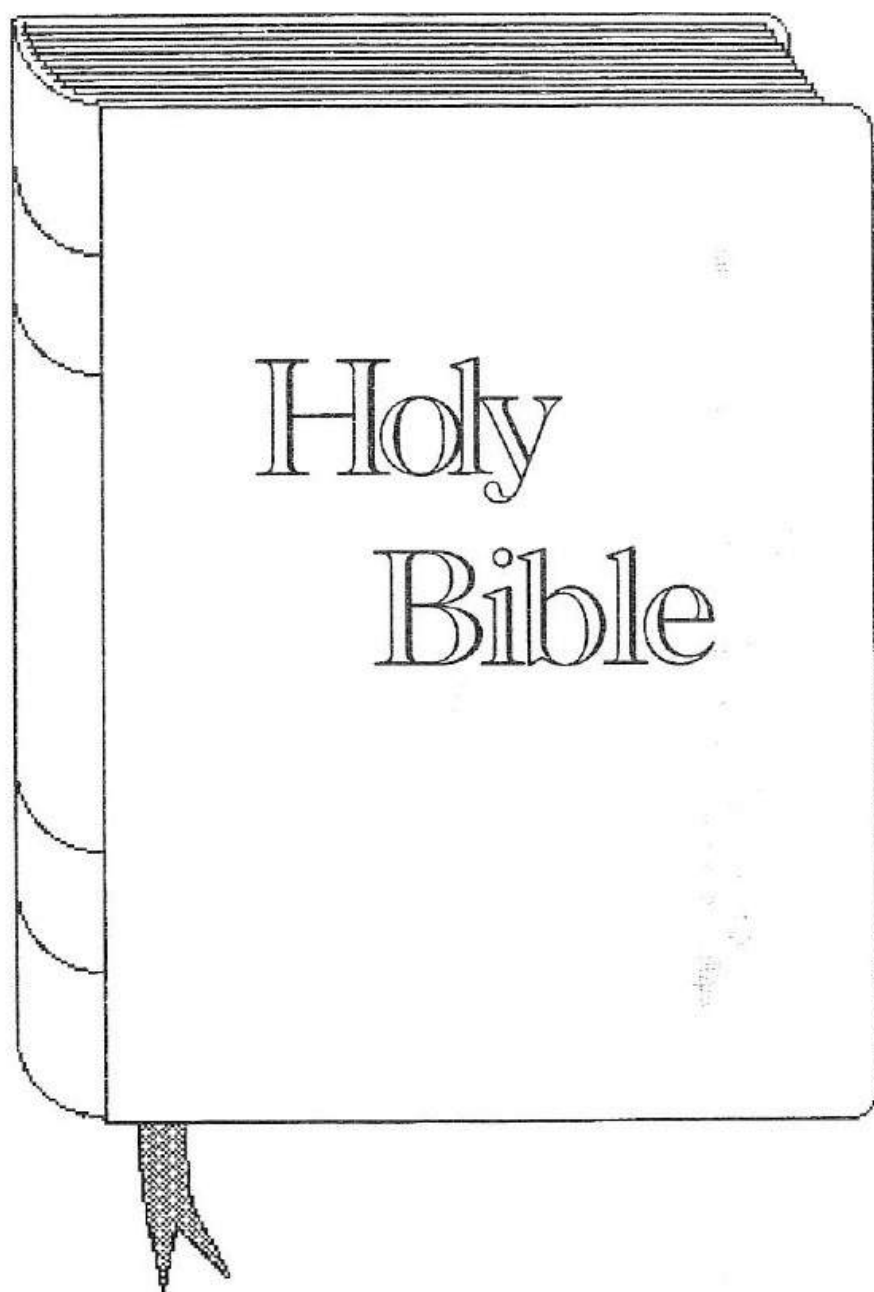

Offering Plate

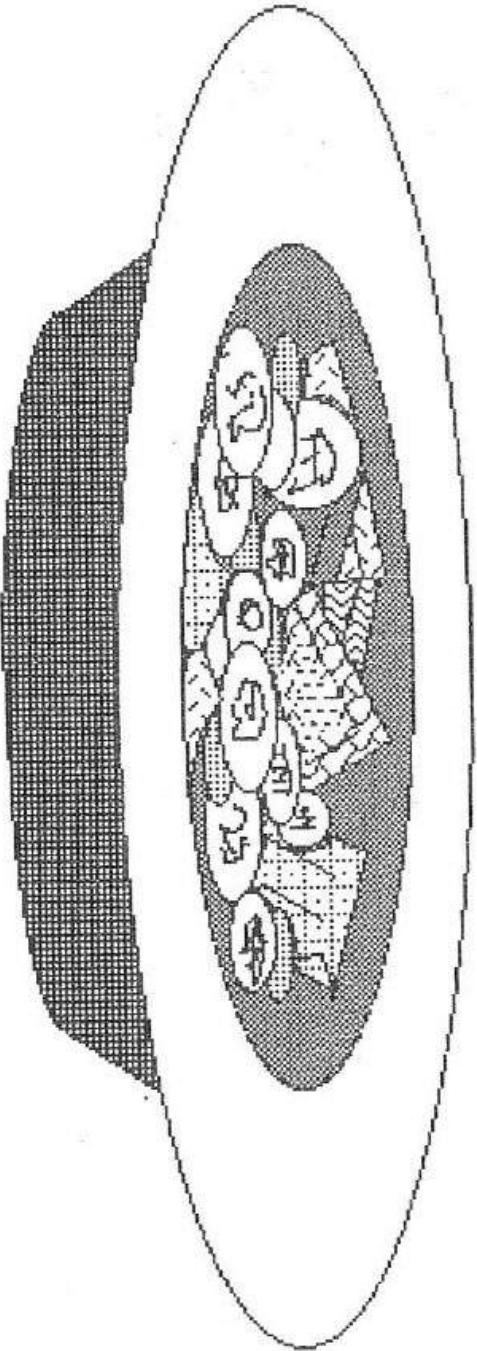

Piano

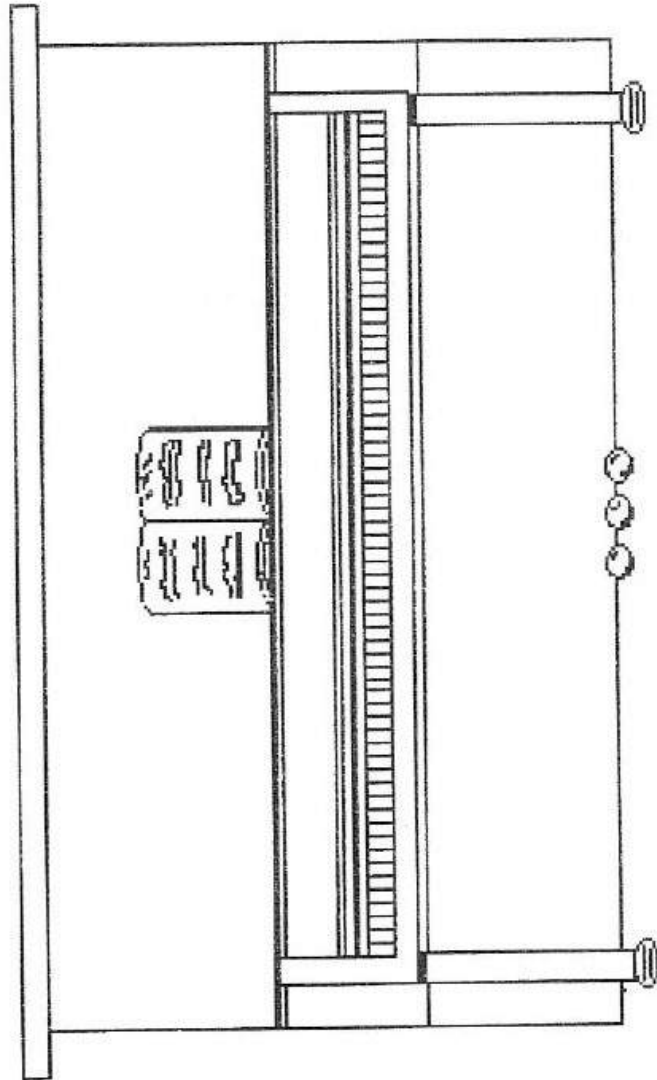

Coloring Book:



Choir Robe and Stole

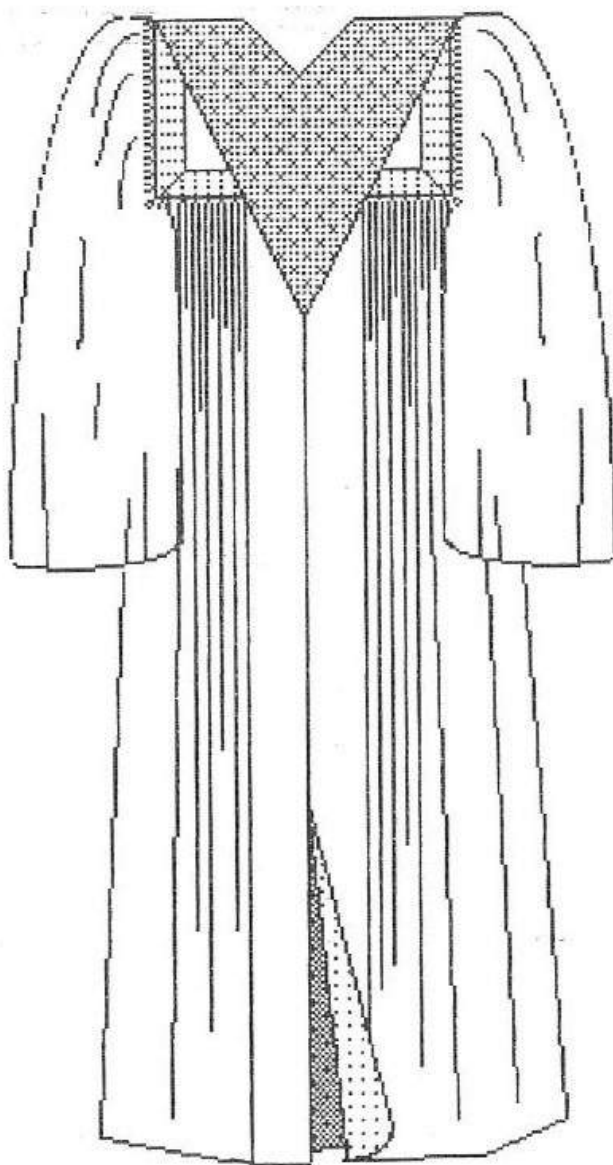

# Minister's Robe and Stole

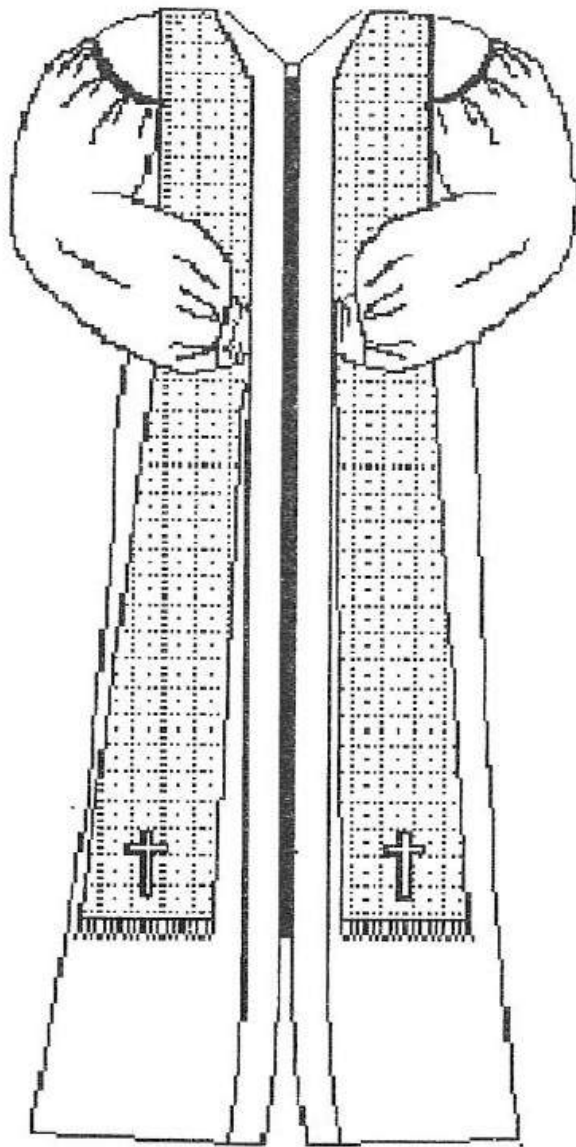

## Coloring Book: Activity Pages

On these pages are the objects or parts of the sanctuary almost sure to be significantly different in every church. You can sketch (or have someone else sketch) these objects or parts of the sanctuary and paste them in. Otherwise, the children can discuss their function and meaning and then draw them themselves.

Draw a picture of your church's bulletin here.

# Chancel

Draw a picture of your church's chancel here.

## Coloring Book: Activity Pages

Extra places and objects can be included to personalize the coloring book to your church environment.

## Stole Pattern:

Stoles which are made by church members are extremely meaningful, especially if each acolyte has one. The time and energy are a constant reminder of the congregation's support of the acolytes' ministry. Choose colors and designs that reflect congregational identity or communicate liturgical seasons.

Presenting the stoles during an installation service during worship symbolizes the authority entrusted to the acolytes. Epiphany, is an excellent time for this service.

Scale:  
1/4" = 1"

Seam Allowance:  
1/4"

Fabric and notions:  
\*Cotton broadcloth or other sturdy, light fabric (2 yds. of 45" wide fabric folded in half lengthwise makes about 5 stoles.)  
\*Matching Thread

### Construction:

1. Cut two pieces for each stole.
2. Sew together (right sides facing) around outside edges.
3. Leave a gap to turn inside out.
4. Turn and press flat.
5. Stitch gap shut.

Cut on fold.

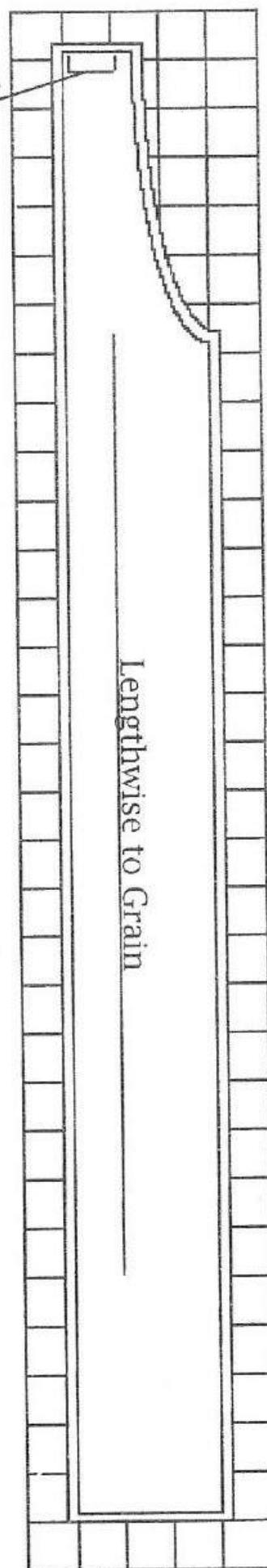

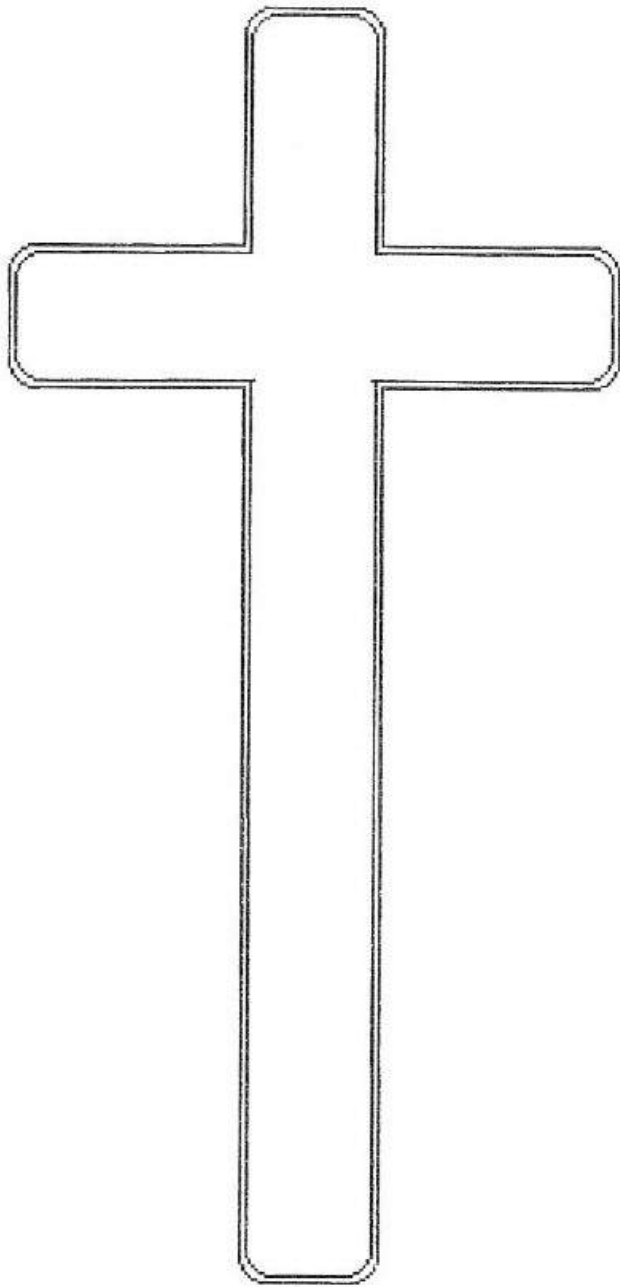

Scale: 1"=1"

Fabric:

Cotton broadcloth  
Double-sided heat  
transfer webbing

### Stole Pattern:

Appliqués of various church symbols may be applied with double-sided heat transfer webbing or by satin-stitching the edges. We have included a candle and a cross. Apply appliqués before constructing stoles.

## Acknowledgements

We gratefully acknowledge the contributions to this work made by the acolytes, leaders and parents of Burgin Christian Church, Burgin KY. Thank you for sharing your sense of adventure with us. We also appreciate the contributions of James H. Trader, II and the staff of the LTS Bookstore. Thank you for keen eyes and humorous critique.

Lisa and Mark Caldwell-Reiss